



ENGLISH

# EPIC 2D

RANGE 0,37÷15 kW  
0,50÷20 Hp

Installation  
and use  
manual

<b>Introduction</b>	
1.1 PRESENTATION	pag. 3
1.2 DESCRIPTION	pag. 3
1.3 HANDLING	pag. 3
<b>Safety informations</b>	
2.1 WARNINGS	pag. 4
2.2 CAUTION	pag. 4
<b>Installation</b>	
3.1 ASSEMBLING	pag. 5
3.2 ELECTRICAL CONNECTIONS	pag. 6
3.3 ADJUSTMENTS AND SETTINGS (INITIALIZATION)	pag. 8
3.4 ADJUSTMENTS AND SETTINGS (ADVANCED MENU)	pag. 10
3.5 TRIMMER SETTINGS	pag. 26
3.6 CONTACT ALARM OUTPUTS	pag. 26
<b>General use</b>	
4.1 KEYPAD AND LIGHTS INDICATIONS	pag. 27
4.2 ALARMS	pag. 28
4.3 TYPICAL INSTALLATIONS	pag. 30
<b>Maintenance</b>	
5.1 PUMPS STOP	pag. 32
5.2 SERVICE	pag. 32
5.3 SPARE PARTS	pag. 32
5.4 WASTE DISPOSAL	pag. 32
<b>Certifications</b>	
6.1 CERTIFICATE OF CONFORMITY	pag. 33

## 1.1 PRESENTATION

The purpose of this manual is to provide the necessary information for the proper installation, use and maintenance of EPIC 2D. The user should read this manual before operating the unit. Improper use may cause damage to the machine and lead to the forfeiture of the warranty coverage. Always specify the model identification code and the construction number when requesting technical information or spare parts from our Sales and Service department. The instruction and warnings given below concern the standard version; refer to the sale

contract documentation for modifications and special version characteristics. For instructions, situations and events not considered in this manual or in the sale documents, please contact our customer service.

Our units must be installed in sheltered, well-ventilated, non-hazardous environments and must be used at a maximum temperature of +40°C and minimum of -5°C.

## 1.2 DESCRIPTION

These control panels are designed for controlling 2 motors or electric pumps used in pressurization systems or in applications for emptying wells or water tanks. In case of any failure of the main pump, the reserve pump start automatically.

voltage protection (V); phase failure protection; start and stop delay; delay network restore, protection delay, frequency 50-60Hz.

**We shall not be liable for any damage caused or suffered by the unit as a result of its unauthorised or improper use.**

## OUTPUT ALARMS AND PROTECTIONS

Acoustic alarm; light alarm, alarm output Relais 220V CA, alarm output Relais 12 V CC, alarm output with Buzzer 12 V; min-max water level; min-max Voltage; phase failure; frequency failure alarm; min-max motor Amperage; min cosφ; motor klixon alarm; water in oil chamber alarm.

## TECHNICAL FEATURES

Self learning of the motor data; min-max amperage protection (A); dry running protection made by cosφ and min Amperage; min and max

## 1.3 HANDLING

**The control panel must be handled with care, as falls and knocks can cause damage without any visible external signs.**

## STORED

If for any reason the unit is not installed and starter immediately after it has reached its destination it must be stored properly. The external packaging and the separately packed accessories must remain intact, and the whole must be protected from the weather, especially from freezing temperatures, and from any knocks or falls.

## PRELIMINARY INSPECTION

After you have removed the external packaging, visually inspect the control panel to make sure it has suffered no damage during shipping. If any damage is visible, inform us as soon as possible, no later than five days from the delivery date.

## 2.1 WARNINGS



### RISK OF ELECTRIC SHOCK

Failure to follow the instructions in this manual, carries a risk of electric shock.



### RISK FOR PEOPLE AND PROPERTY

Failure to follow the prescriptions in this manual, carries a risk of damage to persons and/or property.



### WARNING

Failure to observe the prescriptions in this manual, cause damage to the pump, the unit or the system.

## 2.2 CAUTION



### ATTENTION: PUMPS

- Make sure the pumps are fully primed before you start it.
- Make sure the pumps are running with the correct rotation.
- The electric pumps or the motors can start up automatically.



### ATTENTION: ELECTRICAL CONNECTION

- The control panel must be connected by a qualified electrician in compliance with the electrical regulations in force.
- The electric pumps or the motors and the panel must be connected to an efficient grounding system in compliance with the electrical regulations locally in force.
- Ground the unit before carrying out any other operation.



### ATTENTION: SERVICE

As a general rule, always disconnect the power supply before proceeding to carry out any operation on the electrical or mechanical components of the unit or system.

## 3.1 ASSEMBLING

Fix the control panel for a stable support with screws and screw anchor using the holes arranged in the box (pic. 1) or the fixing bracket if present.

To fix the cables in their terminals use a tool of the proper size to avoid the damaging of the screws or of their seat.

If use an electric screwier pay attention not to spoil the thread or the screws.

After the fixing, remove every plastic or metallic surplus (ex. Pieces of copper of the cables or plastic shavings of the box) inside the box before supplying power.

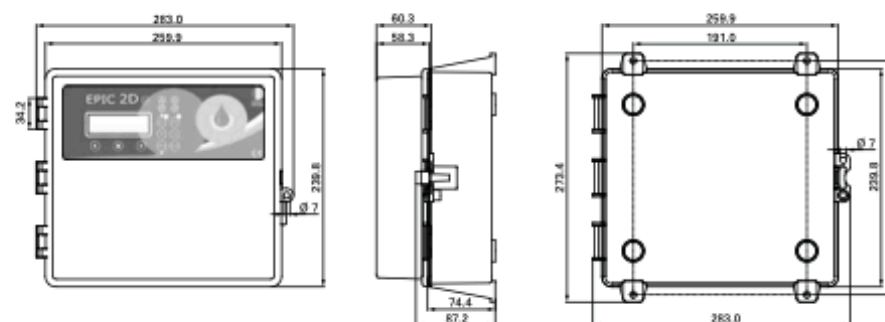

fig. 1

### LINE OF SUPPLY CURRENT

**Connect the unit at ground before carrying out any other operation.**

The voltage input corresponds to the data written on the panel and on the pump:

- (400V ± 10% 50/60Hz x il EPIC 2D -400/...)
- (230V ± 10% 50/60Hz x il EPIC 2D -230)

Make sure that the power-supply-cable can bear the nominal current and connect it to the terminals of the general switch of the control panel.

If the cables are exposed, they must be appropriately protected.

The line must be protected with an Earth leakage and magnetic switch measured in accordance with the regulations locally in force.

### LINE OF MOTOR POWER SUPPLY

**Connect the unit at ground before carrying out any other operation.**

The voltage input corresponds to the data written on the motor:

- (400V ± 10% 50/60Hz three-phase)
- (230V ± 10% 50/60Hz single-phase)

Doing some starting make sure that the motor respects the right direction of rotation usually indicated by an arrow printed on the motor.

## 3.2 ELECTRICAL CONNECTIONS

EPIC 2D 230

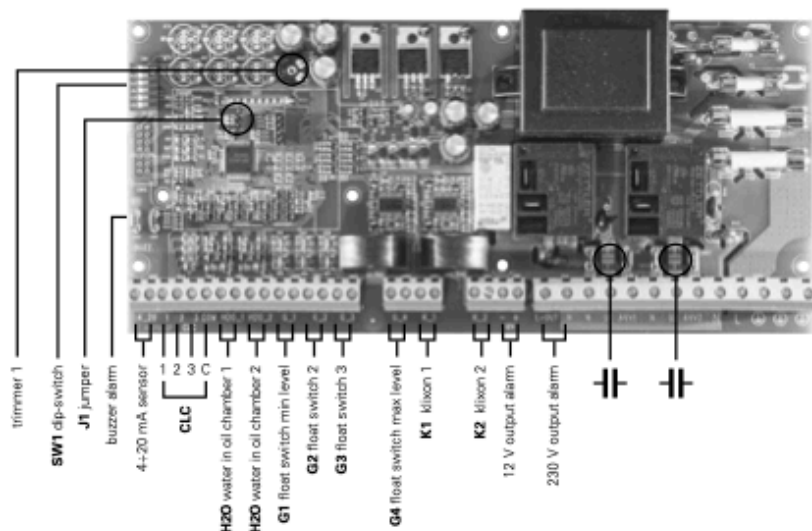
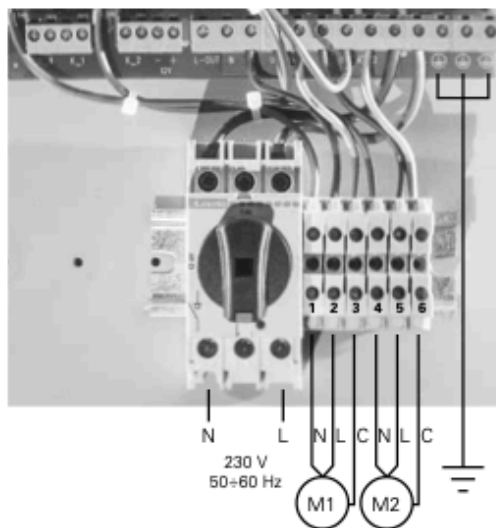

EPIC 2D 400

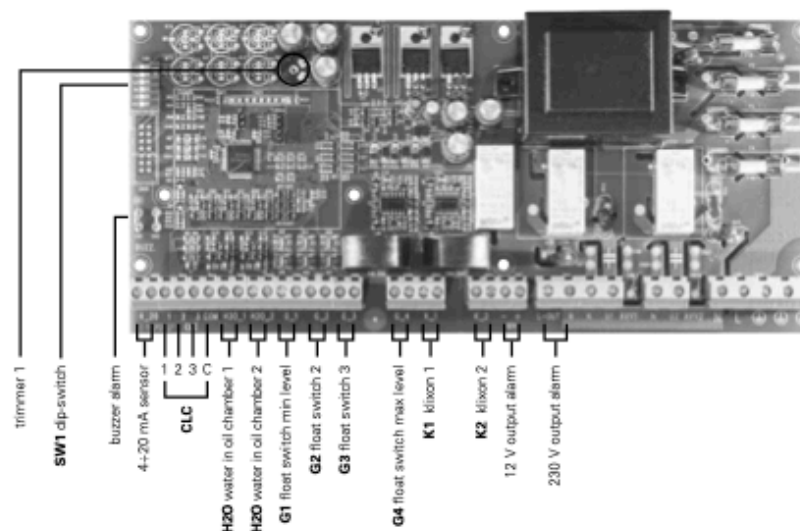
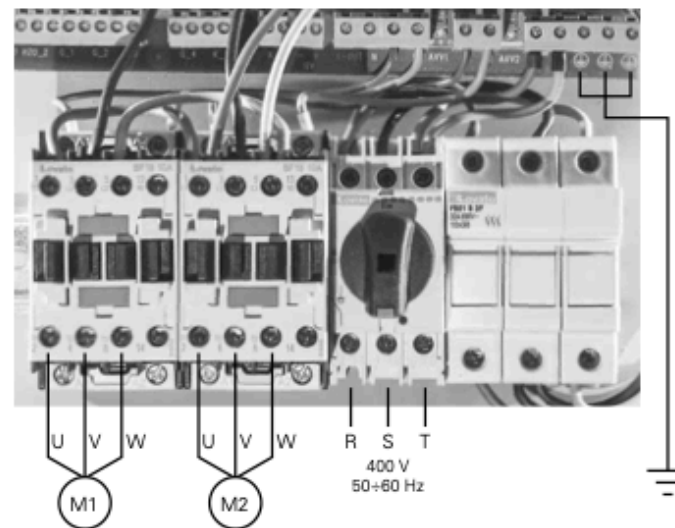

## 3.3 ADJUSTMENTS AND SETTINGS (INITIALIZATION)

### CONTROL PANEL TURN ON



After making all the electrical connections, switch on the control panel and wait for the initial message to appear on the display.

### LANGUAGE SETTING (OBLIGATORY)



Select the display language by scrolling the menu with the appropriate arrows (step 1 and 2).

When completed, press the confirm button (step 3) to continue.

### PUMPS TRIGGER



To proceed with self-learning procedure, the pumps must first be triggered.

**Do not press confirm**, but start the pumps, keeping the "MAN" button pressed (for 3 sec.) for P1 and P2.

### AUTOTUNING (OBLIGATORY)



**To start the self-learning of the pump 1 data, type reply (step 5).**

Once the procedure is complete, type confirmation to proceed (step 6).

For the final confirmation of the data (step 7) type "YES" to go to pump 2, or enter "NO" to go back (to step 5).



Before starting the self-learning procedure, it is necessary to check with a tester that the mains voltage corresponds to the nominal one or at least to the mains voltage.



#### IMPORTANT!

**For each pump, after pressing the final confirmation button, self-learning is no longer possible. To perform the self-learning again it is necessary to access the advanced menu (3.4).**

### CONTROL PANEL OPERATIVITY



Once the self-learning phase is completed, the display of the panel displays the data learned.

By pressing the "AUT" button P1 / P2 the panel becomes operational.

### PRESET PARAMETERS

<b>LANGUAGE:</b> selected	<b>ALTERNATION P1/P2:</b> on
<b>TURN ON DELAY:</b> 2 sec.	<b>OPERATION:</b> emptying
<b>MANUAL KEY:</b> unstable	<b>TYPE:</b> potable
<b>START DELAY:</b> 4 sec.	<b>SELF HOLDING:</b> on
<b>STOP DELAY:</b> 1 sec.	

## 3.4 ADJUSTMENTS AND SETTINGS (ADVANCED MENU)

**ACCESS TO ADVANCED MENU**

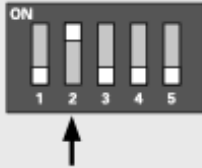

ON

**DIP-SWITCH 2**

The control panel is set as standard with the dip-switch 2 in the "OFF" position. To access the "ADVANCED MENU" and modify the various parameters, **switch off the control panel and set dip-switch 2 to "ON"**. Then turn the control panel back on to display the message on the "ADVANCED MENU" on the display.

SETTING PARAMETERS (OK)

**EXIT**

M01 UTILITY  
M02 GENERAL  
M03 NET CONTROL  
M04 PUMP 1

**M05 PUMP 2**

M06 PROGRAM  
M07 SENSOR  
M08 TIMER  
EXIT

---

**CONFIRM MODIFICATIONS AND EXIT FROM ADVANCED MENU (EXAMPLE)**

LANGUAGE
>ENG

M01 UTILITY
>LANGUAGE

>M01 UTILITY
LANGUAGE

>M01 UTILITY
M02 GENERAL

>EXIT
M01 UTILITY

SETTING
PARAMETER (OK)



ON

**DIP-SWITCH 2**

Once the setting of the various parameters has been confirmed (for example the LANGUAGE parameter), to exit the "ADVANCED MENU" **bring the dip-switch 2 back to the "OFF" position**.

## M01 UTILITY

**ACCESS TO FUNCTION**
**MODIFIED PARAMETERS**

>M01 UTILITY
M02 GENERAL

**LANGUAGE**

Language selection

**START DELAY**

Control panel switch-on delay after restart (in sec.)

**MANUAL KEYPAD**

Possibility of operating the "MAN" button in stable or unstable mode  
ON: unstable  
OFF: stable

---

**CHANGE LANGUAGE**

M01 UTILITA'
>LINGUA

>LINGUA
ITA

LINGUA
>ITA

LINGUA
>ENG

>M01 UTILITY
>LANGUAGE

>EXIT

---

**CHANGE START DELAY**

M01 UTILITY
>START DELAY

>START DELAY
002 SEC

START DELAY
>002 SEC

START DELAY
>102 SEC

>M01 UTILITY
>START DELAY

>EXIT

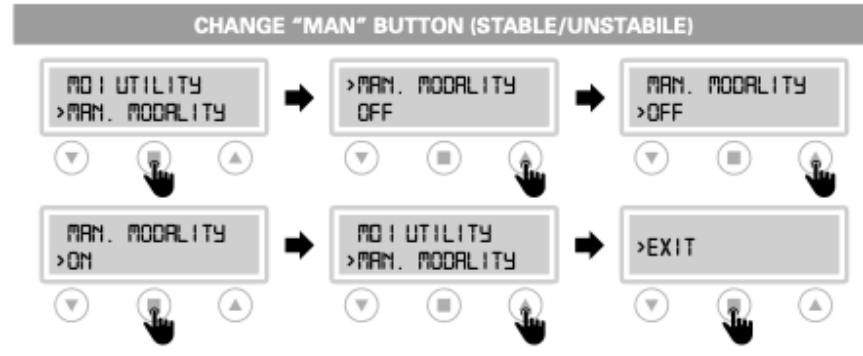

## M02 GENERAL

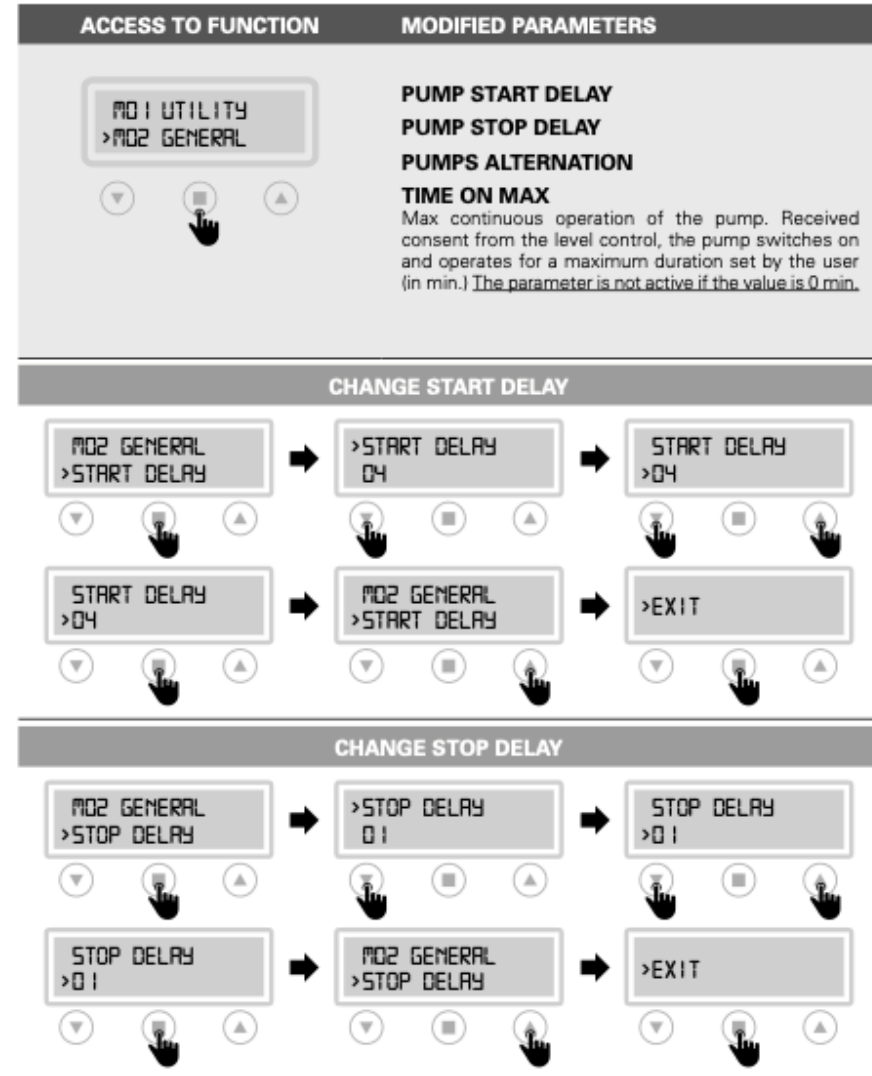

## CHANGE PUMPS ALTERNATION

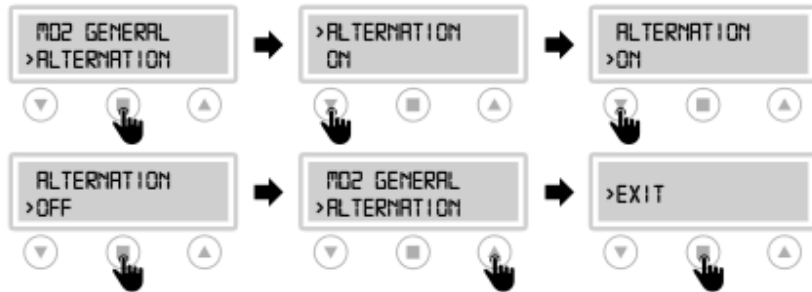

## CHANGE TIME ON MAX

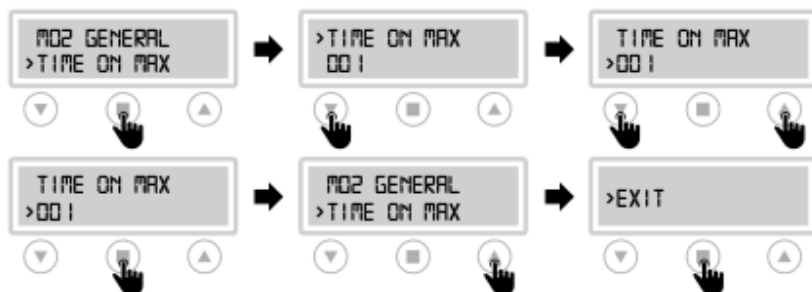

### "TIME ON MAX" PROCEDURE

For a correct functioning of this parameter, perform the following procedure:

- set the pump alternation in "ON"
- set the "STARTING FOR HOURS" parameter from the M04 PUMP 1 menu and then M05 PUMP 2 (see page 18), by entering the maximum number of starts allowed for each pump.

### ATTENTION!

Refer to chapter 4.2 ALARMS for displaying and managing alarms and reset for this parameter.

### EXAMPLE OF OPERATION

Operation of the control panel with "TIME ON MAX" active:

- the pump 1 activates after the buoyant consent, operates continuously and exceeds the max limit of min. set by the user.
- the control panel stops the pump 1 and starts the pump 2 automatically.
- when the same condition occurs again, the control panel stops the pump 2 and restarts the pump 1
- after a certain number of restarts, the control panel blocks both pumps

## M03 NET CONTROL

### ACCESS TO FUNCTION      MODIFIED PARAMETERS



- NOMINAL VOLTAGE
- MINIMUM VOLTAGE
- MAXIMUM VOLTAGE
- NOMINAL FREQUENCY
- FREQUENCY RANGE

### CHANGE NOMINAL VOLTAGE

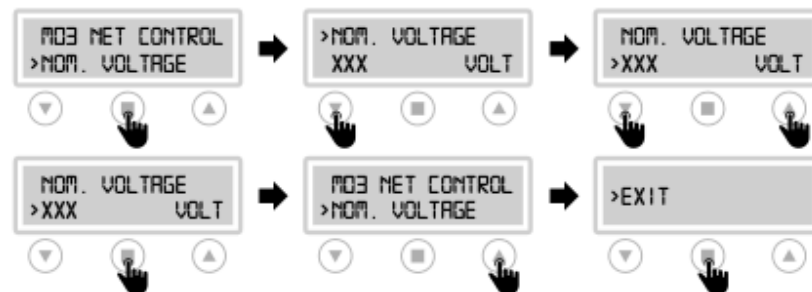

### CHANGE MINIMUM VOLTAGE

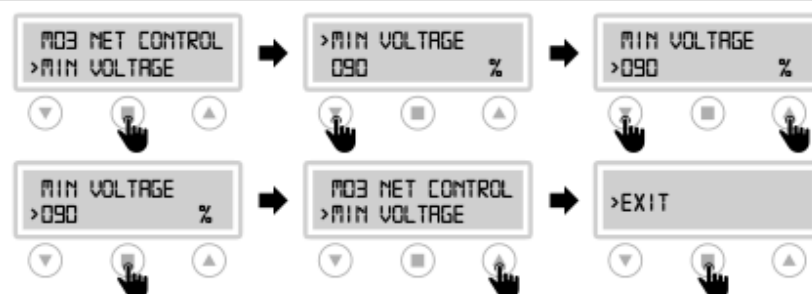



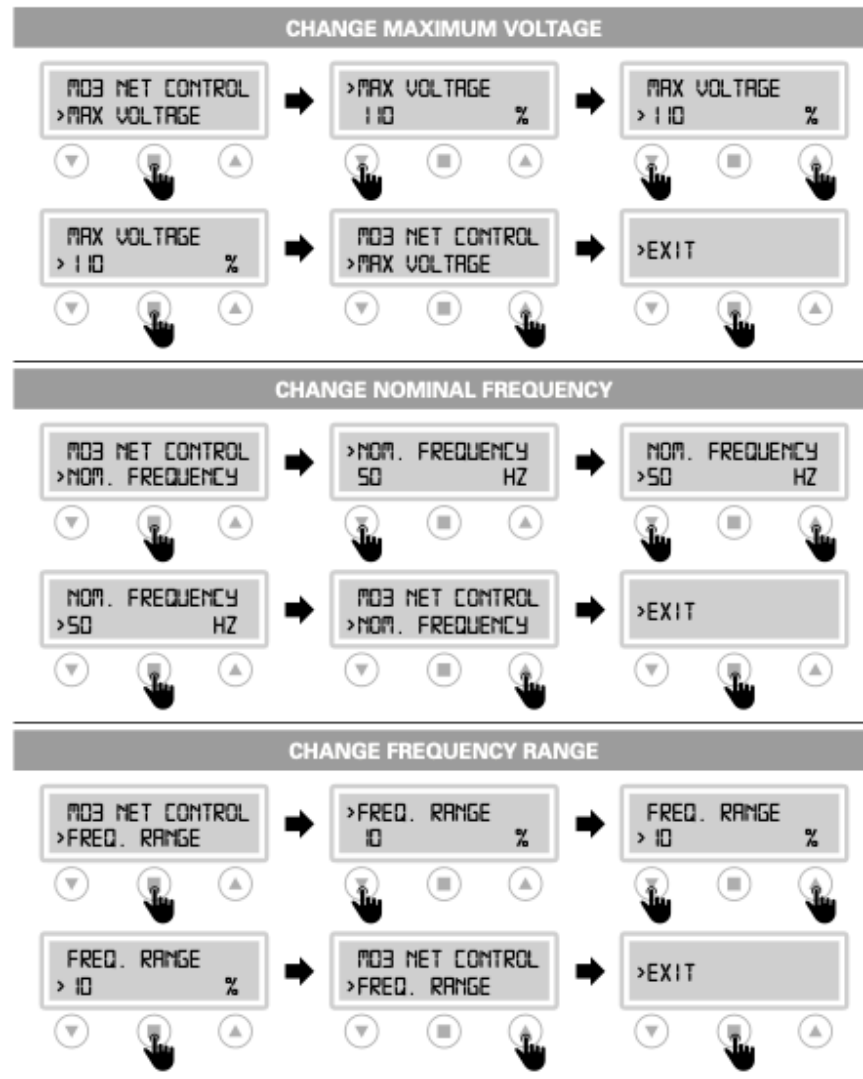

## M04 PUMP 1 / M05 PUMP 2

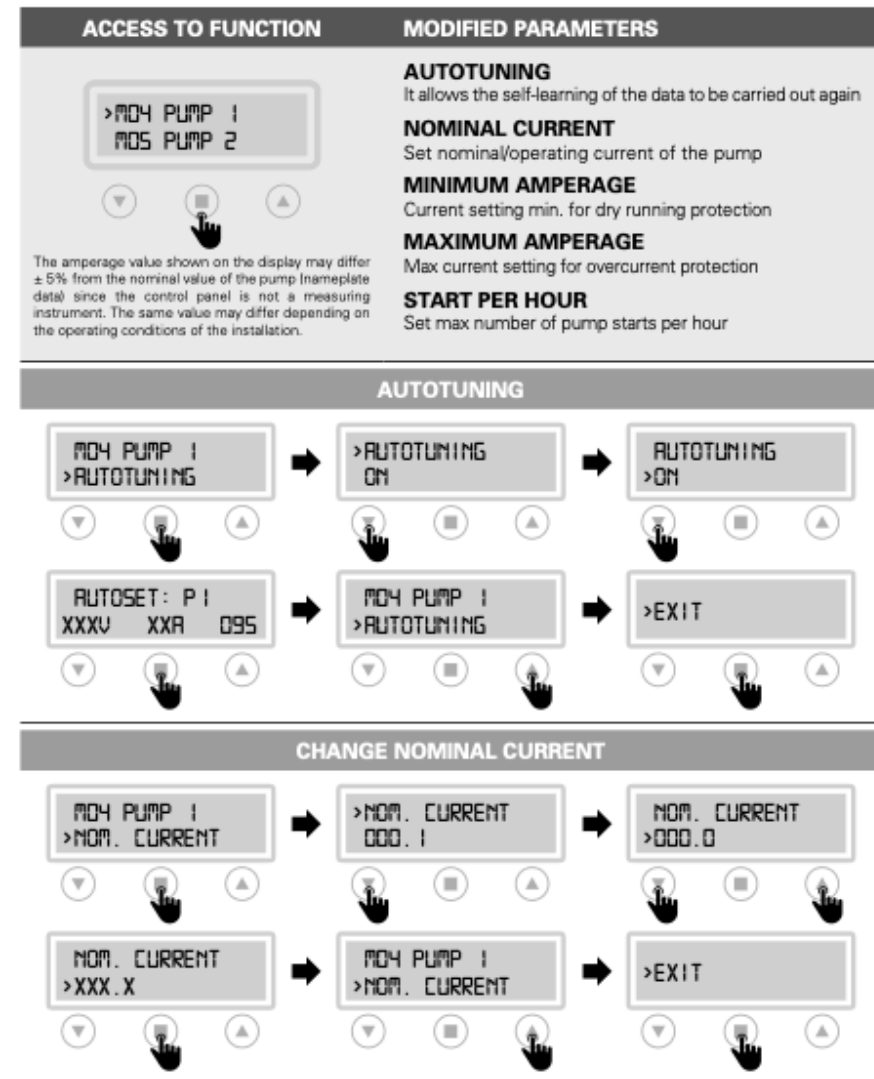

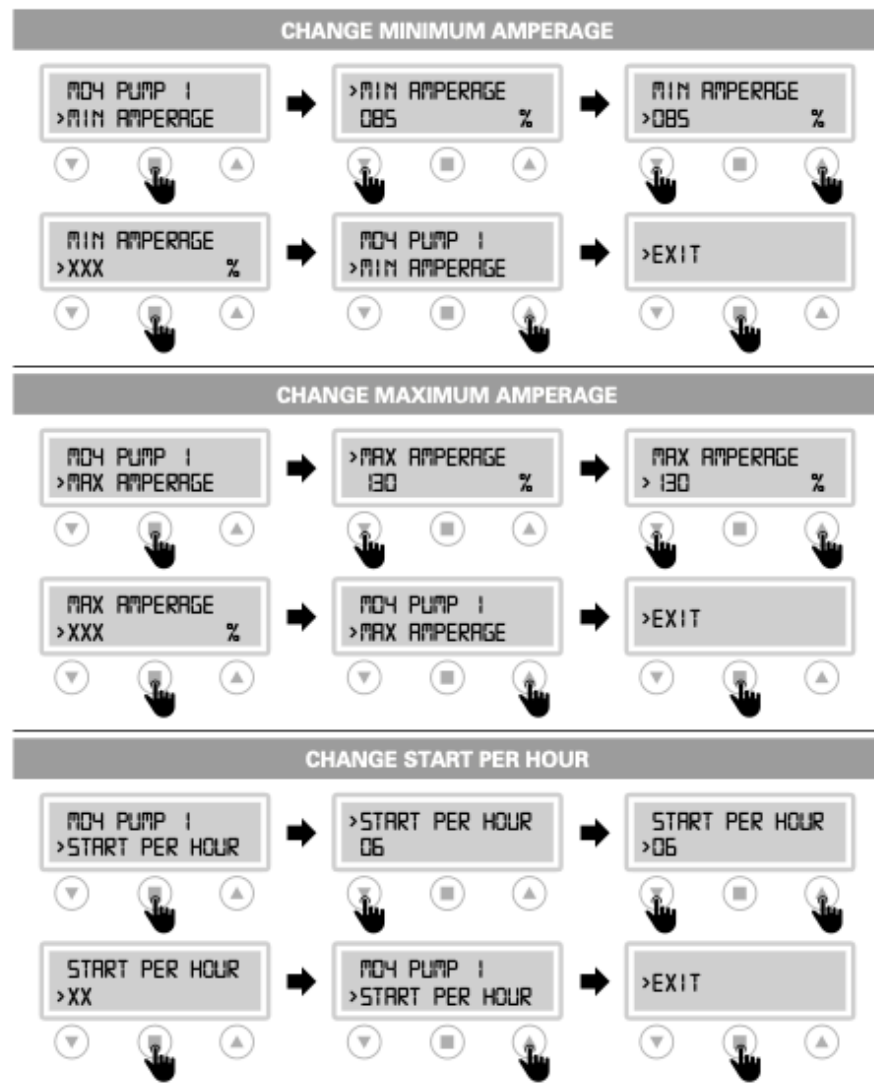

## M06 PROGRAM

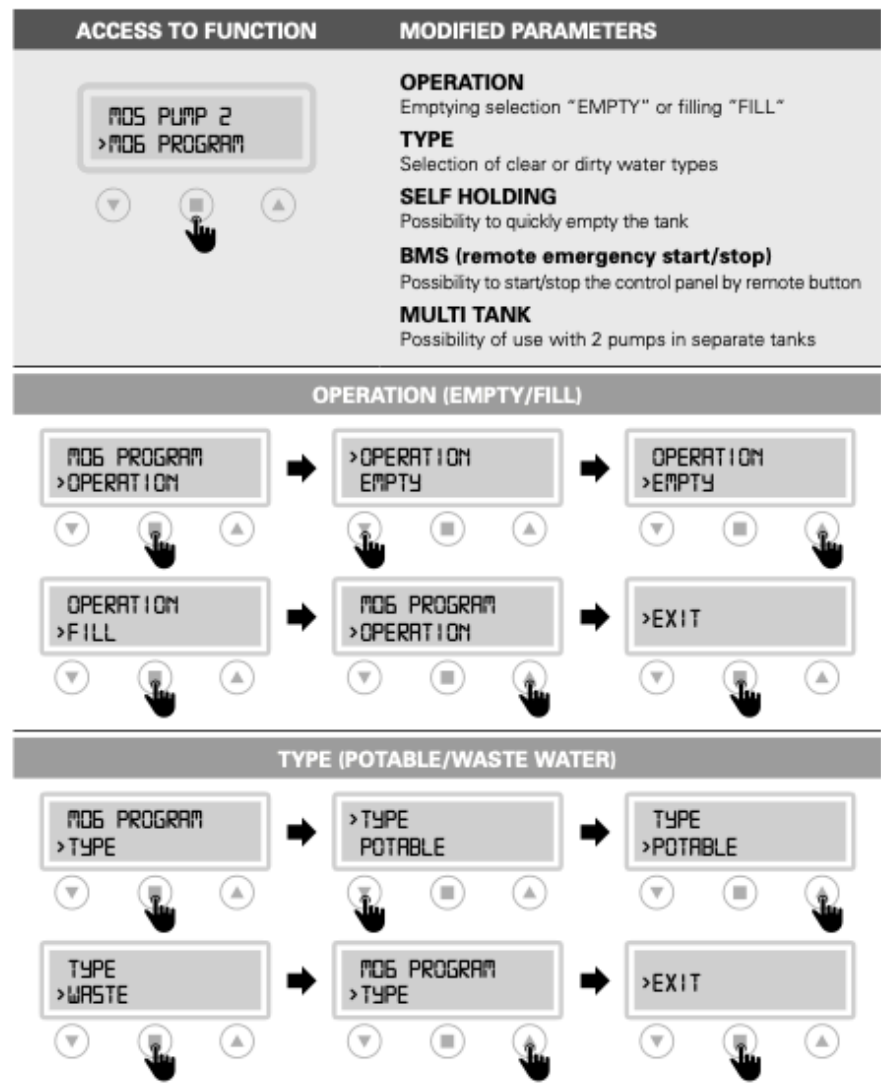

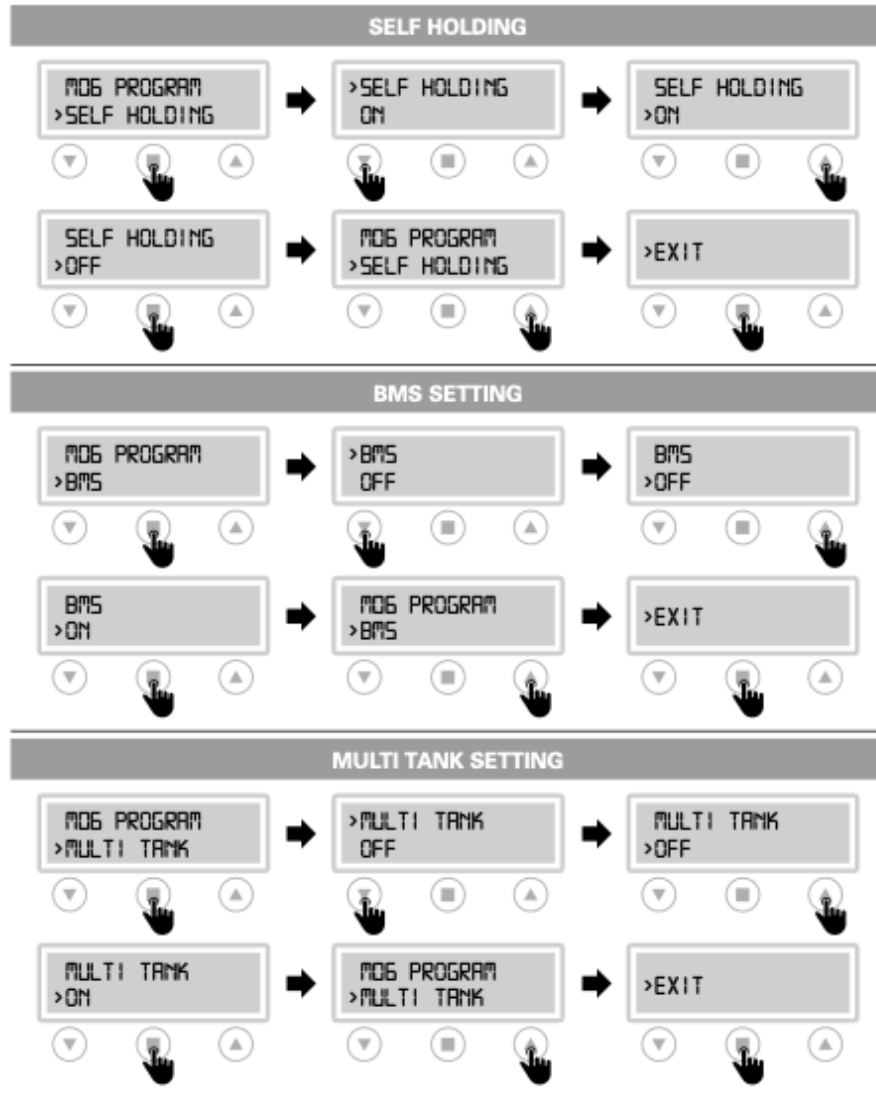

## M07 SENSOR (sensor/transducer 4+20 mA)

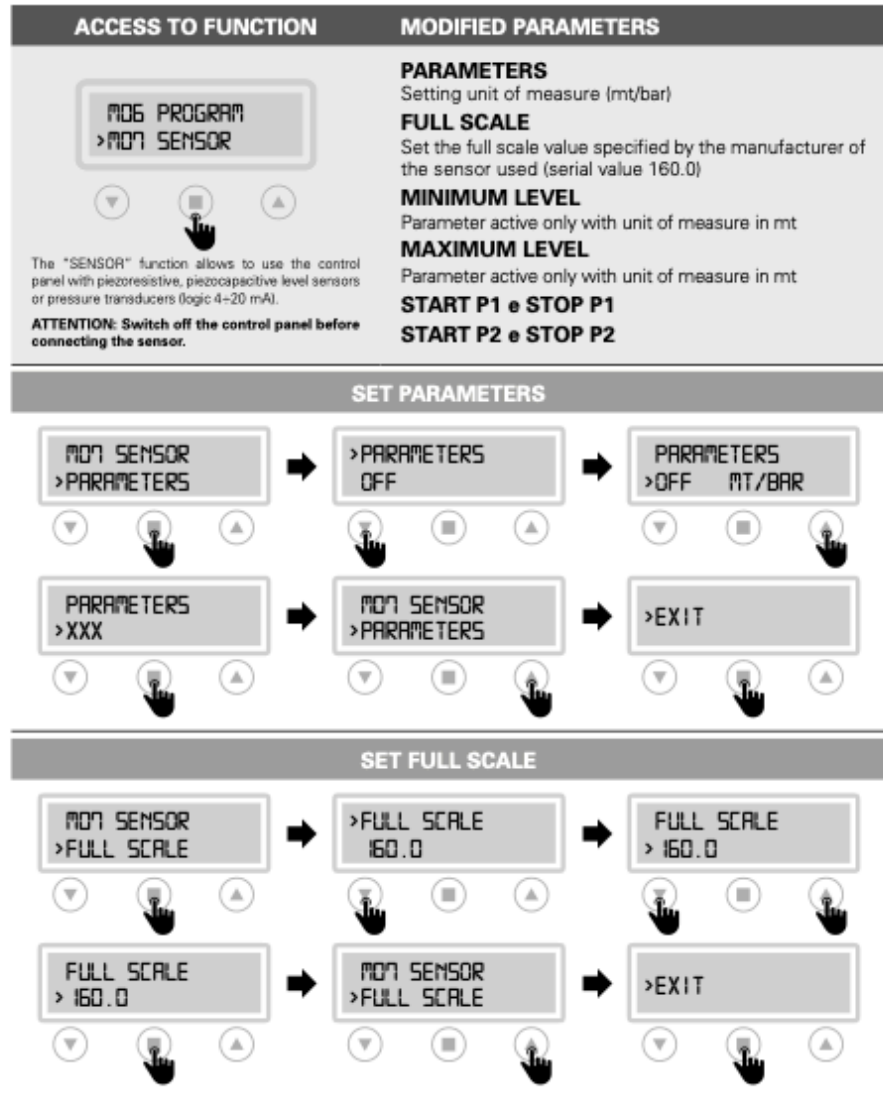

# Installation

EPIC 2D

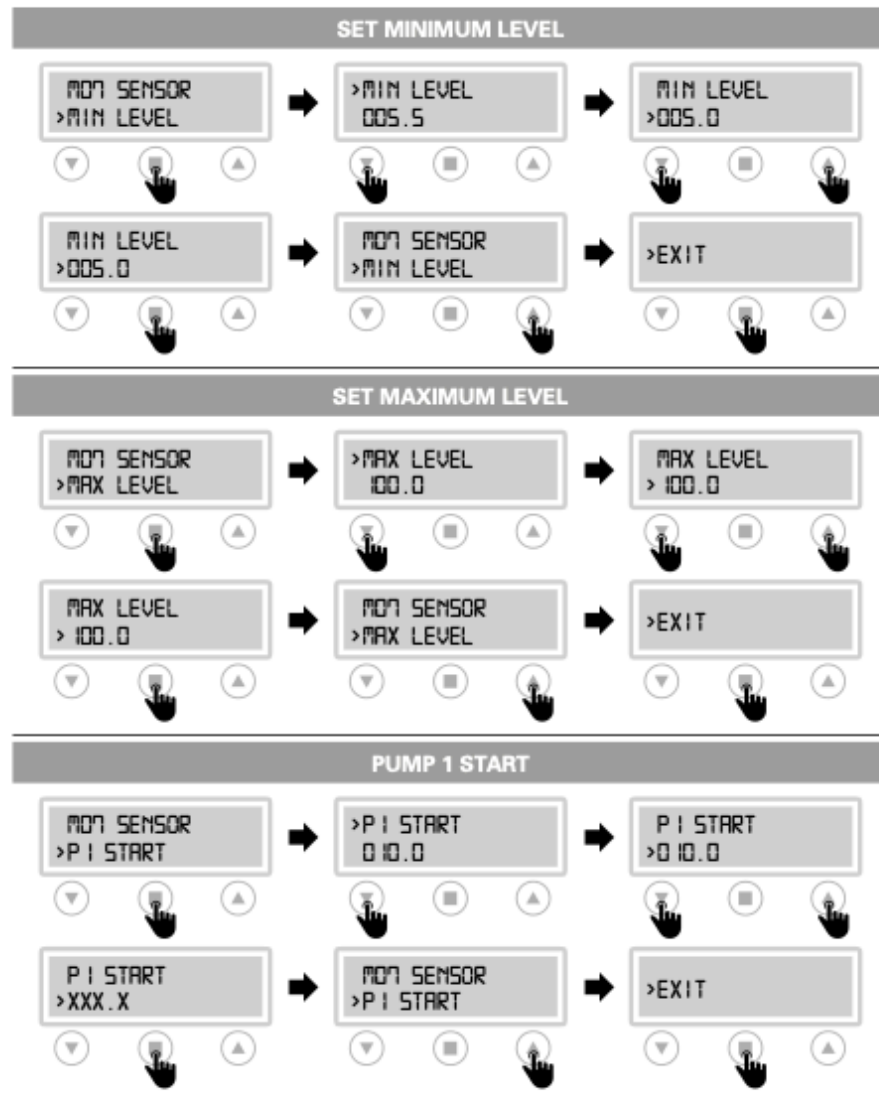

# Installation

EPIC 2D

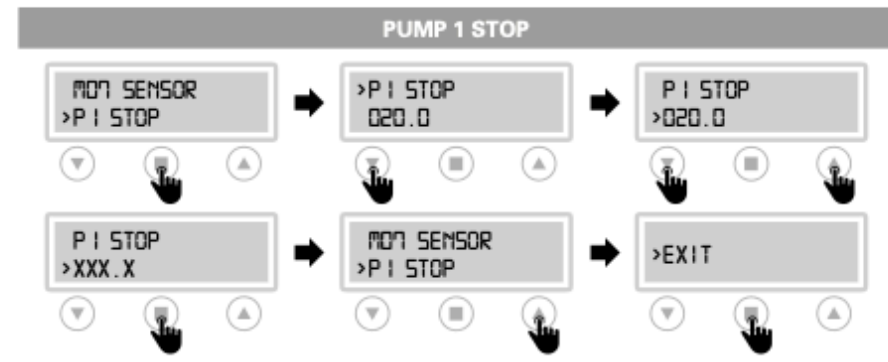

### PUMP START / STOP SETTING 2

It is necessary to carry out the same procedure to set the values of the "START PUMP 2" and "STOP PUMP 2" parameters.

## M08 TIMER

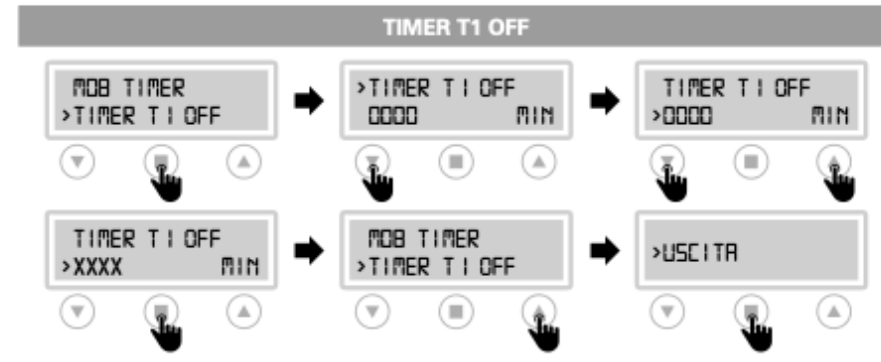
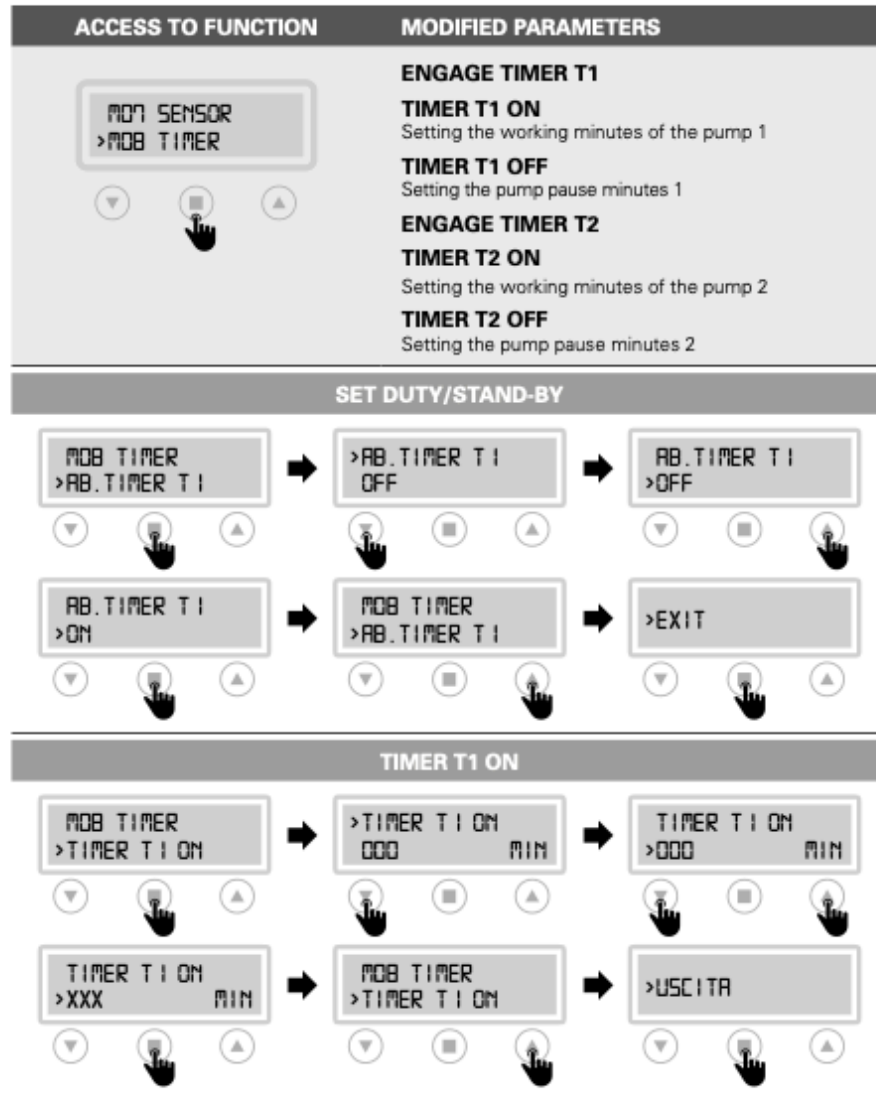

### TIMER SETTING T2 ON / TIMER T2 ON

The same procedure must be followed to set the values of the "TIMER T2 ON" and "TIMER T2 OFF" parameters.

## 3.5 TRIMMER SETTINGS

To change manually the threshold protections, **interrupt the power supply to the control panel** and work on the trimmers, please following the below instructions:



**PROTECTION DELAY**  
The pump protection switching delay has been set at **5 sec.**

TRIMMER SETTING	
	<p><b>TRIMMER 1: PROBE SENSITIVITY CHANGE</b></p> <p>Probe sensitivity (CLC) and water in oil chamber sensor trimmer regulation.</p> <p>It is possible to change the sensitivity of the CLC probes and the water sensor in the oil chamber, <b>interrupting the power supply to the control panel</b> and acting on trimmer 1 (clockwise to increase and counterclockwise to decrease sensitivity).</p>

## 3.6 ALARM CONTACT OUTPUTS

SINGLE PHASE VERSION	TREE PHASE VERSION
<p>Alarm outputs:</p> <ul style="list-style-type: none"> <li>L-OUT / N = 230 V c.a.</li> <li>+ -12 / NO = 12V c.c. or contact NO</li> </ul>	<p>Alarm outputs:</p> <ul style="list-style-type: none"> <li>L-OUT / N = 400 V c.a.</li> <li>+ -12 / NO = 12V c.c. or contact NO</li> </ul>

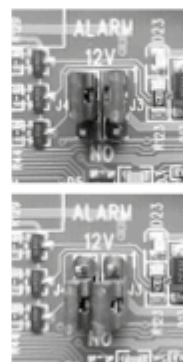
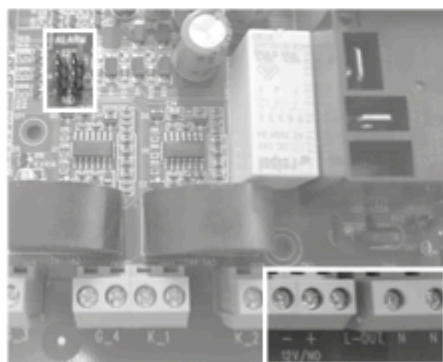

12 V c.c. output

free contact NO

## 4.1 KEYPAD AND LIGHTS INDICATIONS



CONTROL PANEL	
	<p><b>PW</b> blue light indicating power network presence and powered panel.</p>
	<p><b>ALARM</b> red light to indicate a general alarm and pump stop. (min e max Amp, min e max V, min e max level, motor klixon, water in oil chamber, phase failure).</p>
	<p><b>START</b> green light to indicate pump start; fixed on to indicate pump running, flashing to indicate auto-setting mode.</p>
	<p><b>AUT</b> the button activates the auto-setting mode and automatic pump (if the green light is on, the automatic mode is active).</p>
	<p><b>0</b> pump stop button and reset alarms, sound alarm turn-off.</p>
	<p><b>MAN</b> activation of manual pump; holding it down, the engine is operated in by-pass mode, bypassing all the protections.</p>

## 4.2 ALARMS

The control panel signals a series of alarms that may occur during operation. Some of these stop the pumps, while others are only displayed.

All alarms are displayed on the panel (red LED flashing), while the display shows the code/alarms occurred until the cancellation by the operator.

ALARM CODE	ALARM DESCRIPTION	PUMP STOP	RELAY ON	LED SIGNAL
AL 1	MIN VOLTAGE	YES	YES	
AL 2	MAX VOLTAGE	YES	YES	
AL 3	LOW FREQUENCY	NO	YES	
AL 4	HIGH FREQUENCY	NO	YES	
AL 5	DRY RUNNING P1/P2	YES	YES	
AL 6	MAX AMPERAGE P1/P2	YES	YES	
AL 7	MAX STAR PER HOUR	NO	YES	
AL 7	TIME ON MAX + MAX START PER HOUR	YES	YES	
AL 8	WATER IN OIL CHAMBER P1/P2	NO	YES	
AL 9	KLIXON P1/P2	YES	YES	
AL 10	MIN LEVEL	YES	YES	
AL 11	MAX LEVEL	NO	YES	

 The alarm "AL 11" starts all the available pumps.

### ALARM WITH STOP PUMP



Following the detection of an alarm and the consequent blocking of the pump, the control panel provides the following operations:

- Try the first restart after 5 min.
- In case of a negative result, make another attempt after 30 min. and 3 other attempts with intervals of 60 min.
- After 5 attempts if the alarm persists, the control panel permanently blocks the pump and the alarm remains active until the user intervenes.

### DELETE ALARM

P1



P2



To delete the alarms, enter the "0" button for pump 1 once and the "0" button for pump 2.



#### IMPORTANT!

If after having canceled the alarm, the same occurs again, an intervention on the cause is necessary.

## 4.3 TYPICAL INSTALLATIONS

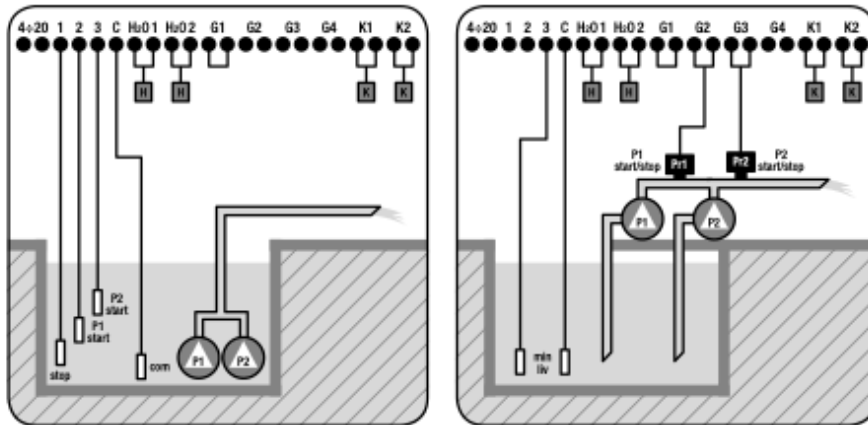
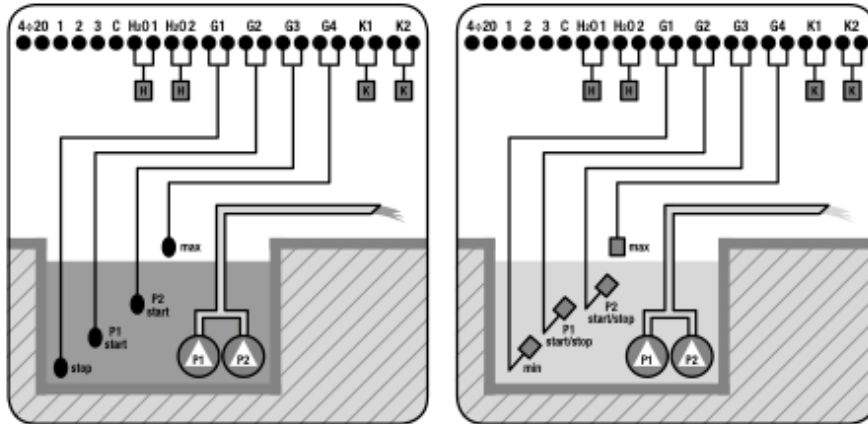

<b>4+20</b>	input for 4+20 mA sensor or pressure transducer
<b>2/3/C</b>	input for level probes
<b>H</b>	input for water in oil chamber sensor/water leakage
<b>K</b>	input for motor klixon
<b>Pc</b>	pressure switch
<b>P</b>	pump

	pressure transducer
	float switch for clear water
	float switch for waste water
	level probes
	4+20 mA piezoresistive sensor

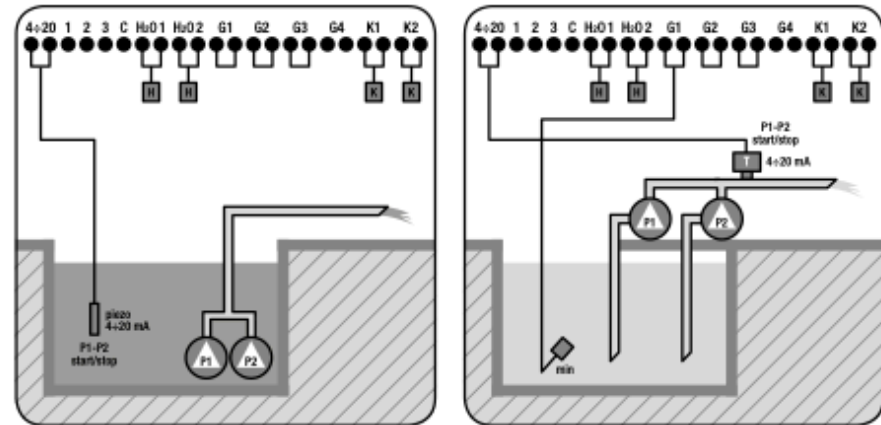
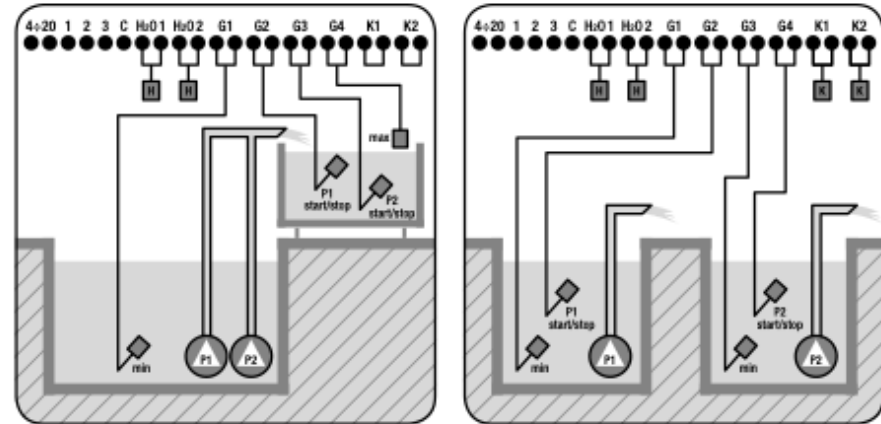



<b>4+20</b>	input for 4+20 mA sensor or pressure transducer
<b>2/3/C</b>	input for level probes
<b>H</b>	input for water in oil chamber sensor/water leakage
<b>K</b>	input for motor klixon
<b>Pc</b>	pressure switch
<b>P</b>	pump

	pressure transducer
	float switch for clear water
	float switch for waste water
	level probes
	4+20 mA piezoresistive sensor



## 5.1 PUMPS STOP

MODE	BUTTON	STOP
MANUAL		The motor stops when the "MANUAL" button is released or once you digit the 0 button.
AUTOMATIC		When the input commands are disable/non active once you digit the 0 button.
OFF		Turning the main switch interlocking door in "OFF" position.

## 5.2 SERVICE

EPIC 2D does not require any routine maintenance provided that their working limits are observed. Any maintenance operations must be performed by qualified and experienced personnel, in compliance with the safety regulations in force.



**DANGER!**  
Make sure that EPIC 2D is disconnected from the power supply before performing any maintenance operations.

## 5.3 SPARE PARTS

Always state the exact model identification number and construction number when requesting technical information or spare parts from our sales and service centre.

Use only original spare parts when replacing any faulty components. The use of unsuitable spare parts can cause malfunctions, personal injury and damage to property.

## 5.4 WASTE DISPOSAL

After the control panel has been installed and started, the customer must provide for the appropriate elimination/disposal of the waste materials according to the legislation locally in force. If the control panel or parts of it must be taken out of service and dismantled, follow local regulations regarding sorted waste disposal. Refer to the appropriate recycling centres.



**CAUTION!**  
Contamination of the environment with hazardous substances such as battery acid, fuel, oil, plastic, copper, etc., may cause serious damage to the environment and endanger people's health.

## 6.1 CERTIFICATE OF CONFORMITY

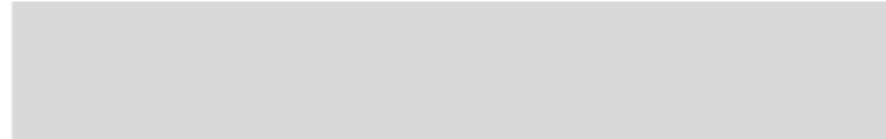

**DECLARES UNDER HIS OWN RESPONSIBILITY THAT THE FOLLOWINGS CONTROL PANELS:**

**EPIC 2D -230 e EPIC 2D -400**

**ARE IN CONFORMITY WITH COMMUNITY DIRECTIVES REGARDING:**

- European directive 2006/95/CE
- Electromagnetic compatibility directive 2004/108/CE



**AND AS APPLICABLE TO HARMONIZED STANDARDS:**

- EN 61439-1
- EN 61439-2
- EN 60204-1
- EN 55014-1
- EN 55014-2
- EN 61000-3-2
- EN 61000-3-3

Moreover Mr. Giuseppe Franchin, as the legal representative of the company, is the person authorized to compile the technical documentation file.

Polverara - Italy, 10/01/2018

Technical Manager  
(Giuseppe Franchin)